



An Efficient Architecture for Ultra Long FFTs in FPGAs and ASICs

- **Architecture optimized for Fast Ultra Long FFTs**
- **Parallel FFT structure reduces external memory bandwidth requirements**
- **Lengths from 32K to 256M**
- **Optimized for continuous data FFTs**
- **Architecture reduces the algorithm to two smaller manageable FFT engines**



Ultra Long FFTs

- **An FFT length that exceeds the internal memory requirements of the FPGA or ASIC**
- **System cost can be reduced in moderate length FFTs in designs where the FPGA/ASIC size is driven by the memory requirements.**
- **This architecture puts most of the storage for the FFT off chip in relatively inexpensive SRAM, reducing the system cost.**
- **Ultra Long FFTs have a similar structure to 2D FFTs**
- **Cooley-Tukey algorithm**
- **Minimizes external memory IC count and bandwidth**



What Ultra Long FFTs Need

The following shows the execution unit (logic) and memory requirement for continuous data FFTs of two lengths:

	1K	1M
Butterflies	10	20
Memory	2K	2M

- The logic requirements for a 1M FFT are only double a 1K FFT, while the memory requirements are 1000 times.
- Logic for 1M FFT easily fits into large FPGA
- Memory requirements exceed what is available even in a large FPGA



Computing $N = N_1 \times N_2$

The $N_1 \times N_2$ FFT can be computed as:

$$X[k_1 N_2 + k_2] = \sum_{n_1=0}^{N_1-1} \left[e^{-j \frac{2\pi n_1 k_2}{N}} \left(\sum_{n_2=0}^{N_2-1} x[n_2 N_1 + n_1] e^{-j \frac{2\pi n_2 k_1}{N_2}} \right) \right] e^{-j \frac{2\pi n_1 k_1}{N_1}}$$

Computing this for:

$$0 \leq k_1 \leq N_1 - 1 \quad \text{and} \quad 0 \leq k_2 \leq N_2 - 1$$

Results in:

$$X[k] = \sum_{n=0}^{N-1} x[n] e^{-j \frac{2\pi nk}{N}} \quad \text{for} \quad 0 \leq k \leq N-1, \quad \text{as desired}$$

$N = N_1 \times N_2$ Architecture

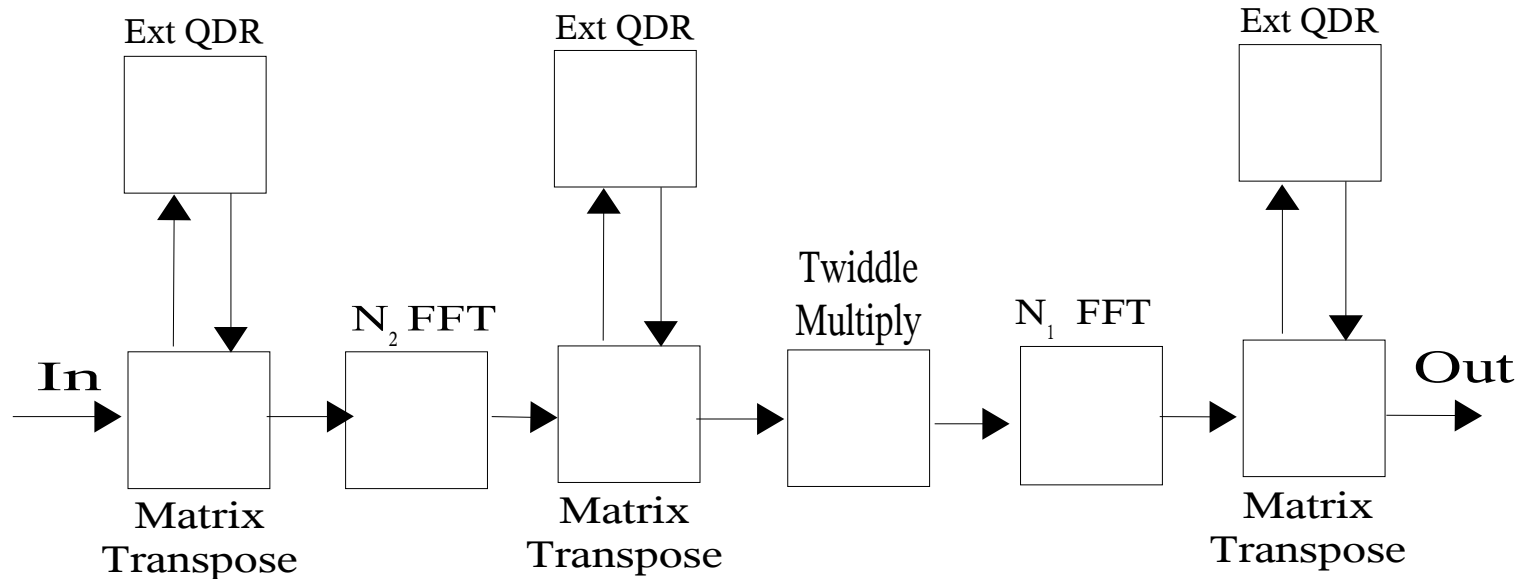

- Three banks of external QDR Memory (single copy each)
- Two continuous data FFTs (N_1 , N_2) inside FPGA
- Twiddle Multiply provides vector rotation between N_2 and N_1 FFTs.
- Final matrix transpose for normal order output.



QDR SRAM

- **Simultaneous read/writes (separate address/data bus) allow single bank of memory per memory transpose.**
- **DDR Style I/O so dual clock edge transfer with FPGA results in narrower data path.**
- **Single copy can be kept at each stage while maintaining continuous data flow.**
- **Special address sequence employed so data isn't overwritten in continuous data application. Reduce IC count.**
- **QDR with Virtex II Pro I/O up to 150MHz (read/write)**
- **QDR II with Virtex II Pro I/O up to 200MHz (read/write)**

CORDIC For Twiddle Factors Generation

- Almost $N/2$ twiddle factors required.
- Very large ROM for FPGA or ASIC.
- CORDIC a natural fit, use coordinate product as input.

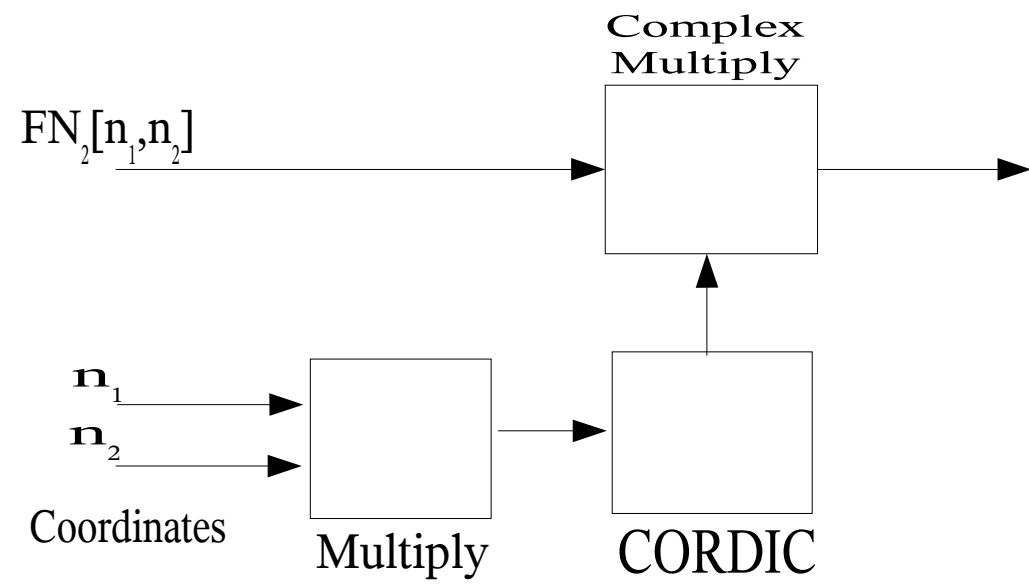

- CORDIC produces the sin/cos terms for angle input.



Matrix Transpose Address Sequence

- Allows single copy for each matrix transpose.
- Operates on continuous data, one point read/written per clock cycle.
- Reduces memory IC count.
- Simple logic for sequence generation.
- Works for square or rectangular matrices.
- Sequence repeats after $\log_2(N)$ sets.
- Write always follows read.
- Simple $N = N_1 \times N_2 = 8$ example:

1 st	2 nd	3 rd	1 st
0	0	0	0
1	2	4	1
2	4	1	2
3	6	5	3
4	1	2	4
5	3	6	5
6	5	3	6
7	7	7	7

- First and last matrix transpose go left to right in table, second right to left.



Fixed vs. Floating Point

- Numbers in radix-2 FFT can grow by $\log_2(N)$, or 1 bit per butterfly rank.
- A 1M FFT can have 20 bits of growth. With 16 bit inputs results would be 36 bits.
- Scaling always required in fixed point versions.
- Fixed point scaling should be limited to every other rank, so 10 times for a 1M FFT producing 26 bit results from 16 bit input.
- Floating point FFT maintains precision without overflowing.
- Floating Point FFT uses approximately 8 times the logic of a similar precision fixed point version.



Virtex II Pro Performance – 512K FFT

- 80MHz Continuous Data
- 1K FFT Engine – 4 butterflies
- 512 FFT Engine – 4 butterflies
- FFT Engines at 160MHz
- QDR memory at 80MHz
- Real 14 bit input, complex 24 bit output
- Virtex II Pro – Device Usage
 - Slices - 12,500
 - BlockRAM - 144
 - MULT18x18 – 88
- Fits in XC2VP40



Other Uses of Architecture

- **2D FFT – Remove first matrix transpose and twiddle multiply.**
- **Variable Length – Use variable length FFTs and dynamic matrix transpose blocks.**
- **Mixed Radix FFTs – Substitute other than radix-2 for 2nd FFT.**
- **Performance increases easy with parallel input radix-2 FFTs and multiple paths to SRAM.**



Other Dillon Engineering Resources

- **ParaCore Architect (parameterized core builder)**
- **DSP Algorithms**
 - **Mixed radix FFTs**
 - **2D FFTs for image processing**
 - **Fixed or floating-point FFTs**
 - **Floating point math library**
 - **AES Cryptography**
- **System level DSP**
 - **OFDM Transceivers**
 - **Radar Processing on single FPGA**
 - **Image Compression/Processing**
- **Hardware/Software SOC**
 - **High speed Ethernet Appliances**
 - **Linux Based SOC in FPGA**
 - **MicroBlaze application**